

Stitching Needle Point Timber Screw

Head Style: Hex Flange Head

Drive Type: Hex

Material: Hardened Steel

Class Grade: Class 2

Finish: Zinc Plated

Corrosion Protection Level: Moderate

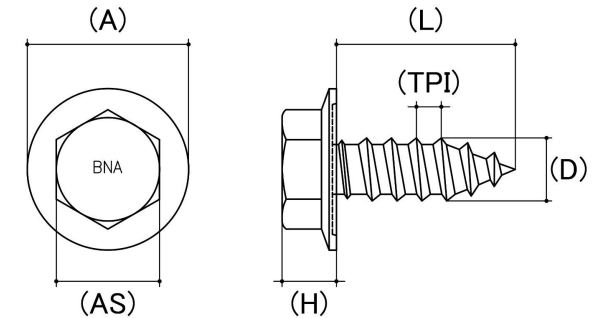

*CAD drawings shown for graphic representation only.**

Size	Thread Pitch (TPI)	Thread Type	Product Diameter (D) (mm)		Head Diameter (A) (mm)		Head Height (H) (mm)	Driver Bit Size (AS) (inches)	sku (qfind)
			Min	Max	Min	Max	Nom	Nom	
8g (4.20mm)	15	Coarse	4.00	4.20	9.90	10.20	4.10	1/4	07STH81512

Disclaimer:

Dimensional data and technical information was obtained from publicly available sources and not acquired through standard agencies. It has been completed and compiled for reference purposes only; where discrepancies are found they are subject to change without notice. Bolt & Nut Australia makes no warranties or representations regarding the accuracy and validity of the compiled information and data. Contact the relevant standard authorities for accurate and detailed information.

* CAD drawings may not reflect diameter, thread length or overall length.

© Bolt & Nut Australia Pty Ltd. All rights reserved.

Version: 18 Mar 2024